

AXIAL WAREHOUSE EXHAUST FAN
 ARRANGEMENT 4, LEVEL 1, VERTICAL DISCHARGE, CEILING HUNG

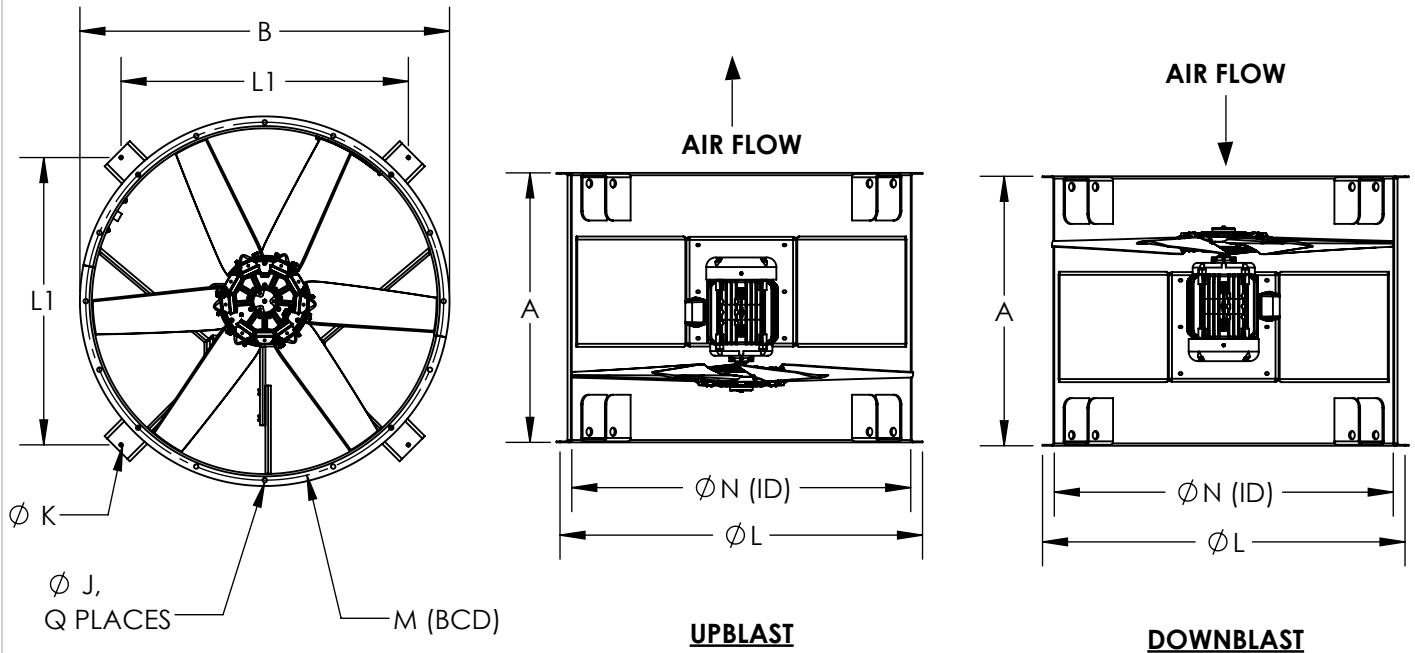

STANDARD CONSTRUCTION:

1. High efficiency adjustable pitch, cast aluminum airfoil propeller (06 or 09 blades)
2. Bolted access door
3. Bolted switch bracket
4. Air dry enamel coating

ACCESSORIES

1. NEMA 3R service switch
2. Mounting rails
3. Vibration isolators
4. Extended lubrication lines (PVC or copper)
5. Drain
6. Companion flange
7. Inlet bell
8. Inlet/outlet guard
9. VFD

DIMENSIONAL DATA:

SIZE	A	B	I	J	L	M	N	Q	L1	MIN. MTR FRAME	MAX. MTR FRAME	UNIT WEIGHT (LESS MOTOR)
AWX-1600	49 1/8	67 3/8	13/16	13/16	67 3/8	65 1/4	63	16	52 3/8	213T	286T	975

ALL DIMENSIONS ARE INCHES AND WEIGHTS IN LBS.